



INSTALLATION INSTRUCTIONS



'08-'14 DODGE CHALLENGER SRT 8 | PART NO. 15134

BILL OF MATERIALS:

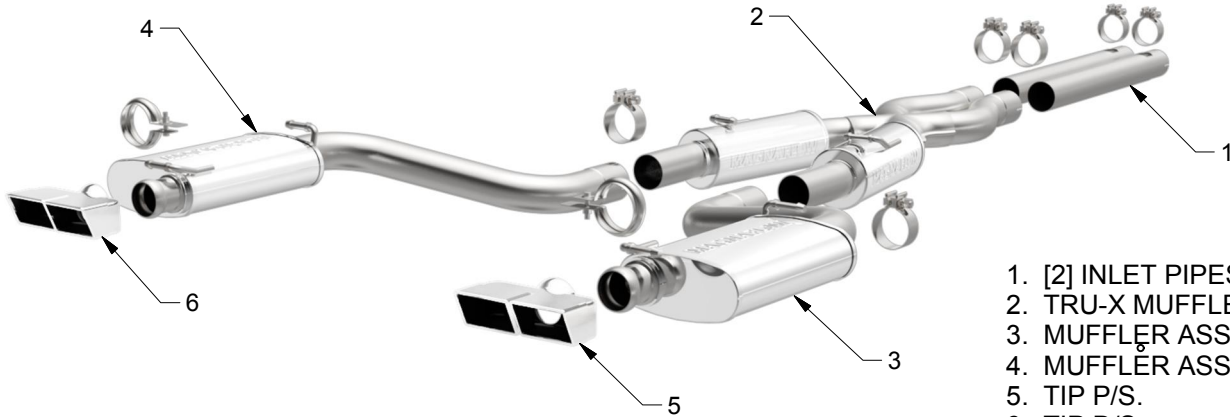

1. [2] INLET PIPES
2. TRU-X MUFFLER ASSY.
3. MUFFLER ASSY P/S.
4. MUFFLER ASSY D/S.
5. TIP P/S.
6. TIP D/S.



WEAR SAFETY GLASSES



READ INSTRUCTIONS THOROUGHLY BEFORE INSTALLING PRODUCT

SHOP SUPPLIES:



SPRAY LUBRICANT

To ease removal of existing exhaust components (especially on older vehicles) spray penetrating lubricant on all fasteners and hangers/insulators that will be loosened or removed and let soak before disassembly.

HARDWARE KIT:

1. [4] 3.00" Clamps
2. [2] 2.75" Clamps
3. [2] 3.00" Ball Clamp
4. [2] Bolt M8-1.25x35mm

MINIMUM REQUIRED TOOLS:



Pry Bar



12mm Socket
13mm Socket
15mm Socket

MAGNAFLOW RECOMMENDS PROFESSIONAL INSTALLATION ON ALL THEIR PRODUCTS



WARNING: When working on, under, or around any vehicle exercise caution. Please allow the vehicle's exhaust system to cool before removal, as exhaust system temperatures may cause severe burns. If working without a lift always consult vehicle manual for correct lifting specifications. Always wear safety glasses and ensure a safe work area. Serious injury or death could occur if safety measures are not followed.

ATTENTION: Always install any supplied band or U-bolt clamps to the proper torque specifications of 40-45 ft-lbs for band clamps and 30-35 ft-lbs for U-bolt clamps. Over tightening will result in the clamp breaking and will NOT be warranted by MagnaFlow.

INSTALLATION INSTRUCTIONS

OEM UNDERBODY REMOVAL

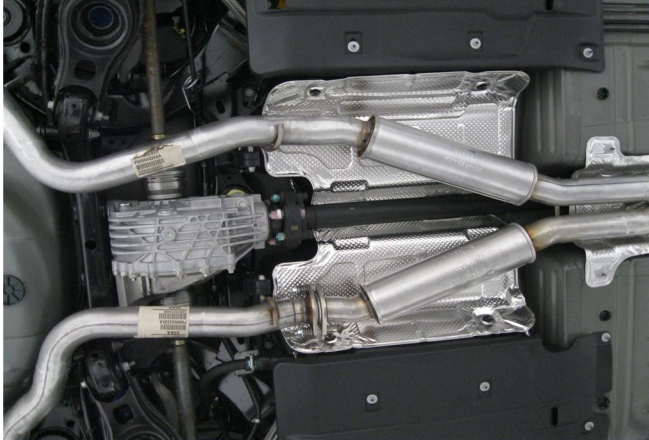

Step 1. Begin removing the OEM exhaust by unbolting the coupling flange of the drivers side muffler with a 13mm socket.



Step 2. Unbolt the two rear hanger assemblies also with a 13mm socket. The drivers side muffler assembly may now be removed. Continue by unbolting the clamps at the catalytic converter outlet with a 15mm socket. Remove the welded hangers from the rubber insulators using a pry bar. do not discard or damage the insulators as they will be needed to install your new system.



Step 3. Unclip the ground strap from the passengers side rear muffler hanger assembly. Then, remove both hanger assemblies as on the drivers side using a 13mm socket. The remaining exhaust may now be removed.



INLET PIPES AT CATALYTIC CONVERTER OUTLETS

Step 4. Begin installing your new MAGNAFLOW system by attaching the two inlet pipes to the catalytic converter outlets using the supplied 2.75" Clamps. Secure loosely with a 15mm socket.



TRU-X MUFFLER ASSEMBLY

Step 5. Next attach the Tru-X muffler mid pipe assembly using the supplied 3.00" clamps. Secure loosely with a 15mm socket.



Step 6. Insert all hanger assemblies into the rubber insulators for for both passengers and drivers side muffler assemblies. Now using the supplied 3.00" clamps loosely secure them to the Tru-X assembly.



TAIL PIPE DETAIL

Step 7. The design of the new system allows for either the supplied quad tips or reuse of the OEM tips. Choose the desired look for your vehicle.



OEM TIP



QUAD TIP



Step 8. Attach each tip to the muffler outlet ball flare using the supplied ball clamp and bolt. Loosely secure using a 12mm socket.



FINISHED INSTALLATION, REAR VIEW

Step 9. Once a final position has been chosen for the new system, evenly tighten all fasteners from front to rear using the torque specifications on page one of this document. Inspect all fasteners after 25-50 miles of operation and retighten if necessary.